

AC Motor Drive Vector Control

RM6G1/RM6G1e Series

Multi-function Vector Inverter 0.4kW~500kW



All-around Motor Drive Technology

Product series are fully upgraded to keep up with the newest trend of motor control methods

Vector Control Technology

Control core includes sensorless vector control technology which can precisely control motor without encoder. And besides that, using encoder pairs with Vector control technology can easily achieve the demand of fast speed response and accurate speed control. Meanwhile, it can also achieve simple position control and zero-speed control.

With static Auto-tuning, inverter can get the motor parameter or use dynamic Auto-tuning if you need more accurate system parameters. This technology can effectively decrease adjustment downtime and optimize the matching between motor and inverter.

Applications

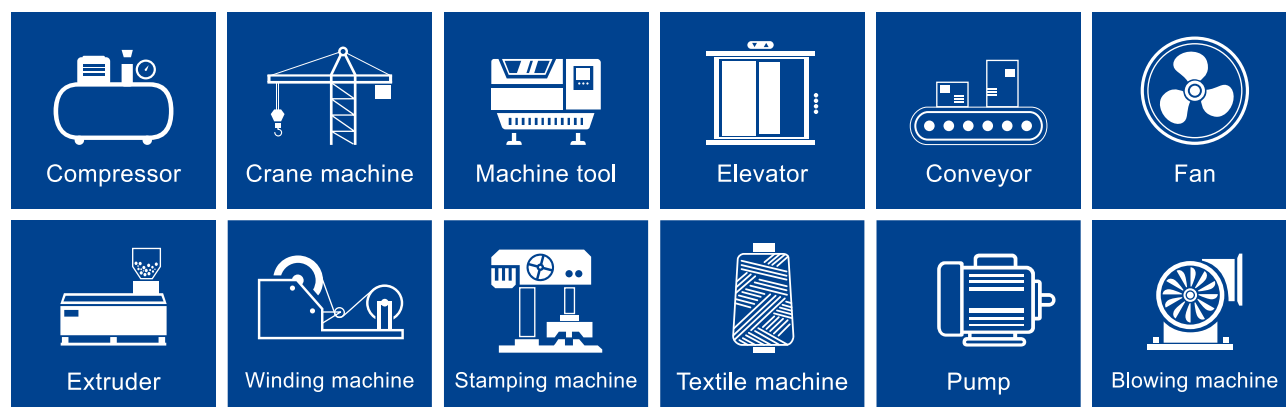

6 in 1 Motor Control

	V/F Control	V/F Control+feedback*	IM Sensorless vector control	IM vector control*	PM Sensorless vector control	PM vector control*
Speed control range	1:40	1:120	1:120	1:1500	1:100	1:1500
Speed control accuracy	±3%	±0.02%	±0.2%	±0.02%	±0.2%	±0.02%
Speed response	3Hz	3Hz	>10Hz	>50Hz	>10Hz	>50Hz
Start torque	150% @ 3Hz	100% @ 0.5Hz	200% @ 1Hz	200% @ 0Hz	100% @ 2% rated speed	200% @ 0Hz

This table are affected by motor spec, control structure and characteristic. For reference only.

*RM6G1e doesn't support encoder speed feedback.

High Compatible and Adaptable

RM6G1 series offer various solutions which trustworthy

Normal Duty Mode and Heavy Duty Mode in One Inverter

You can set inverter to normal or heavy duty mode with parameters.

Multiple Communication Interfaces

Built-in RS-485 Modbus, the fastest communication speed is 115,200 bps. And besides that, it supports multiple communication cards to help you handle data and manage your machine.

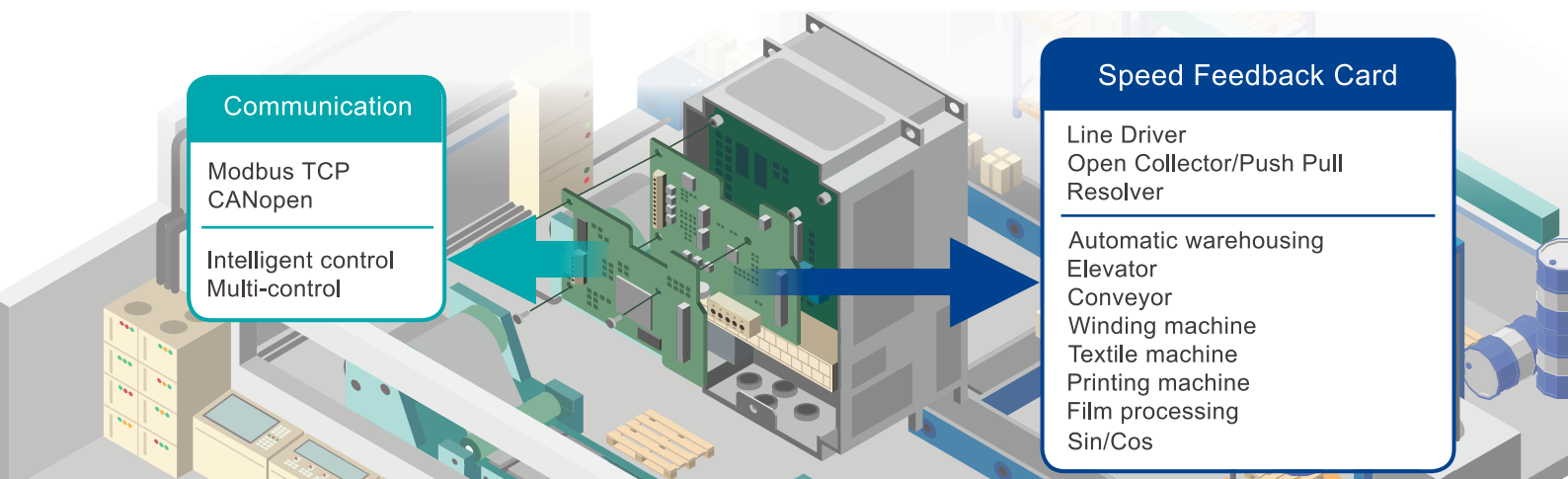

Various Control Experience

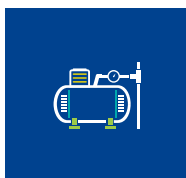

PID Control



Air Compressor, HVAC, Pump

Built-in two-stage PID control function, including speed, pressure, flow, temperature control...etc. If inverter doesn't need any PID control, it can be shared with other machine to reduce cost.

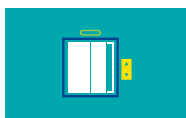

S-curve Control



Elevator, Conveyor

S-curve control can improve the comfortability and stability of elevator.

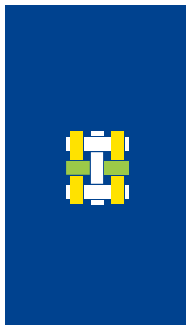

16 Sets Sequence Control



Dryer, Mixer, Textile Machine

It can set up with some algorithms, such as cycle, count, direction, time to simplify the PLC setting.



Pulse Input and Output



Stamping Press Machine, Textile Machine, PLC Application

Built-in one set pulse input and output terminals to expand the scope of application.



Torque Control



Winding Machine

This control method can keep tension stable, restraining the looseness and uneven of winding.

Safety Is Our First Priority

Safety is one of the most important function of inverters. Rhymebus never compromise

Functions for Reliability

Sudden Interruption of Power Supply

- Built-in speed search function. When a power supply recovers, it can automatically start to reach to the original speed. Suitable for fan, blowing machine... etc.
- KEB: When inverter detects the interruption, it can automatically control the motor to stop without power supply. This function can avoid the motor in the free run situation and cause the equipment damage. Suitable for machine tools.

Surge Countermeasure

Built-in power and surge absorber can effectively reduce the damage done by high voltage surge.

Motor Overheat Protection

Pair with various temperature sensor (PTC / NTC/ PT100/ RTD392/ KTY84), inverter can send warning or even stop machines when the motor is overheated.



Safety

In Line with International Standards

Full series complies UL/cUL (UL61800-5-1, CSA C22.2 NO.274), RoHS 2.0 and REACH.

Safe Torque Off (STO)

Built-in STO function constructs high safety system. In the meanwhile, it has safety switch output terminals, too.

Safety Function

Built-in safety functions, such as stall prevention, overvoltage suppression, over exciting braking, high slip braking, dynamic braking.

Inverter – Not Only Saving Energy

Simplifying wiring, reducing space usage and cost

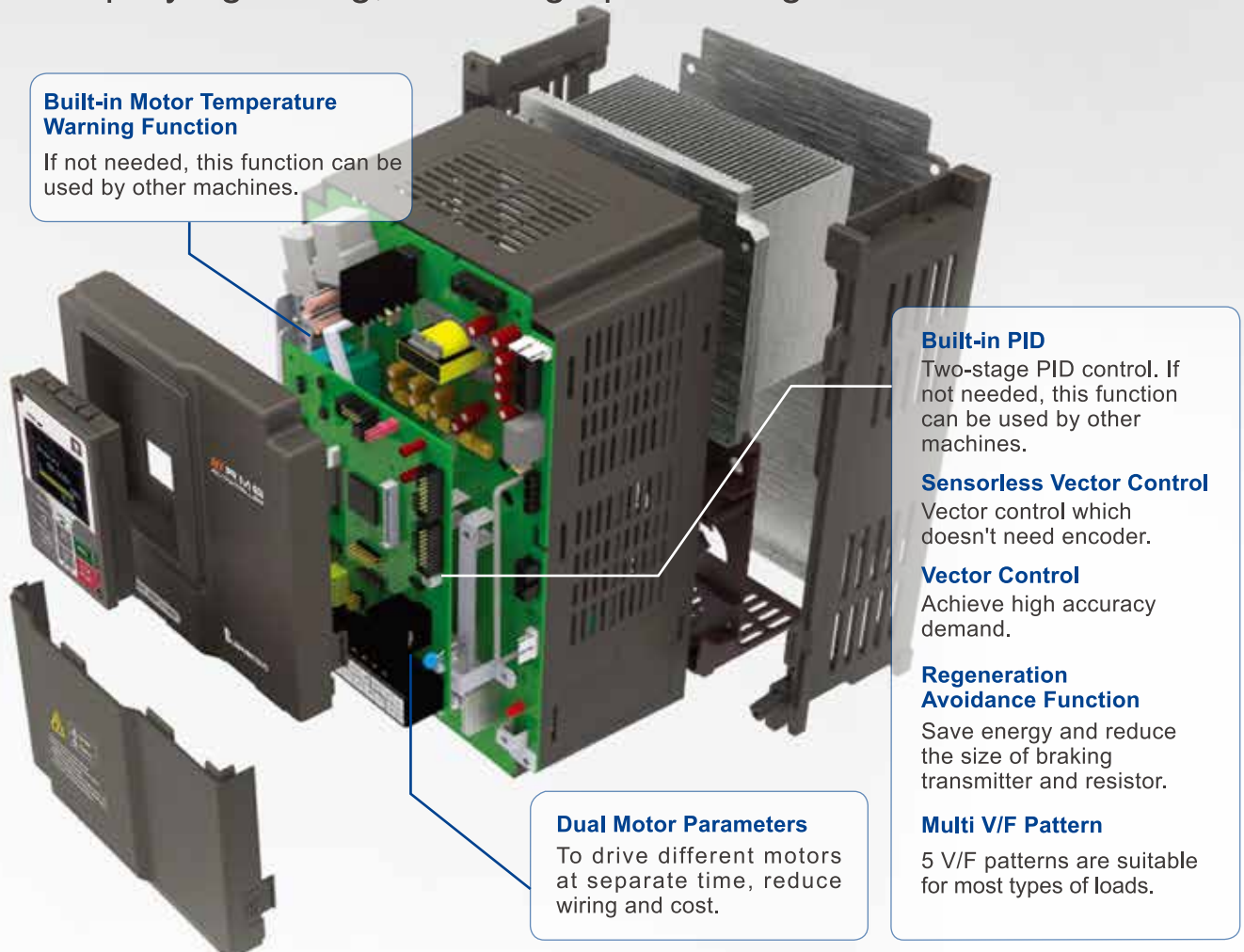

Enhanced Energy Saving - Power Regeneration

Replace braking resistor with RM6A6 (power regenerative unit) to regenerate regen-power of motor back to grid. Reduce the cost and heat of braking resistor and keep machine operation smooth and safe at the same time.

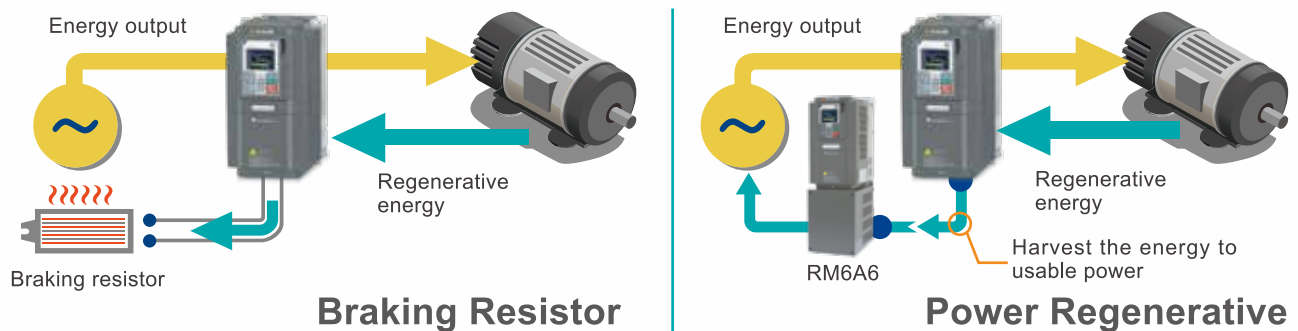

Suitable Machines: High inertia, four quadrant loads, rapidly deceleration and constant braking. For example, textile drafting machine, Plano machining center, elevator, lifting crane, stamping press machine and automatic warehouse system.

Intelligent Parallel Operation: Automatically detect DC voltage level, capable of connecting multiple RM6A6 in parallel to match different motor spec without interfering operation.

High Speed Accuracy at Steady State

Speed deviation at steady state can be below 0.05%, which is suitable for automatic warehouse system, textile machine, metal sawing machine and servo injection molding machine.

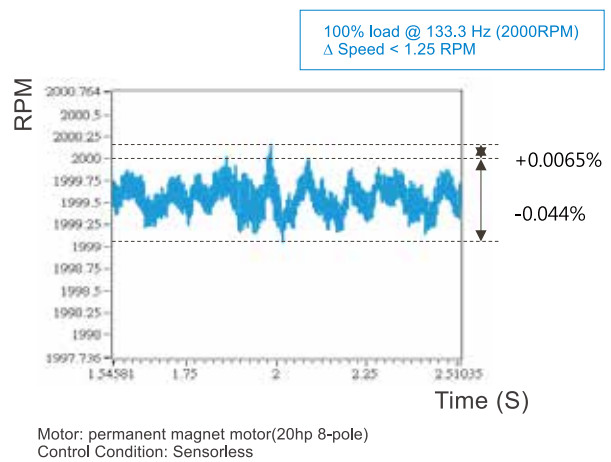

High Torque Output

Using sensorless vector control is able to achieve 200% rated torque at extreme low speed. Suitable for high starting torque or heavy-duty machine such as construction works machine, tunnel boring machine, air compressor, drilling machine, elevator or crane.

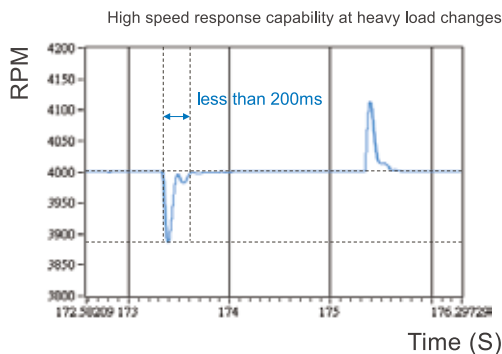

Swift Compensation of Speed at Changing Load

Motor speed will suddenly decrease as load increases, this reduces the quality of processing. With high speed response capability, inverter can drive motor back to the setting frequency in short time. Suitable for stamping press machine, air compressor, metal bandsaw machine and servo hydraulic system.

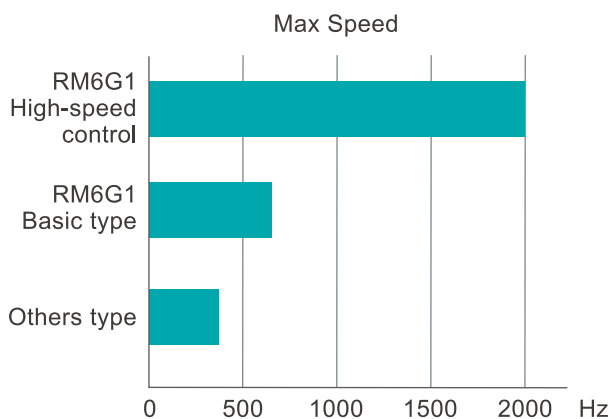

High Output Frequency

RM6G1 standard series can reach 599Hz, high speed series can reach 2000Hz. Suitable for high speed spindle, optical polishing and active magnetic bearing centrifugal compressor.



Intuitive Design

We listen our users's advices to help user find the shortcut they need

Keypad Evolution

LCD KP-602 supports full color LCD display and multiple languages. It can display text on the screen and can display full parameter name which will reduce the workload when adjusting parameters.

Parameters Grouping

To optimize parameter setting speed, we group parameters according to their functions.



PC Tool Optimize Management

Rhymebus PC tool uses Microsoft Windows as the main platform, which can manage and store parameters. Speed up maintenance process.

Bluetooth Control

With Bluetooth module and Android app, users can control inverters at dangerous field remotely.

Overall Factory Management

Predictive Maintenance

RM6G1 series can record 10 sets of error histories, each history can record up to 16 statuses which make problem solving easier. It can also set temperature warning level. Besides, in all series cooling fans can be controlled to run at starting or temperature setpoint.

Rich Operating Information

RM6G1 series offer lots of data during operation to help you manage the factory, including kWh accumulation value, energy usage, power factor and operation/electric supply time.

Keypad Introduction

Full color LCD & multilingual keypad
KP-602 (optional)

1 **Light on:** primary frequency command is set up by keypad or UP/DOWN terminal.
Light off: Primary frequency command is set up by multi-functional terminal.

2 1. Enter the function setting mode.
2. Back to the monitor mode.

3 1. Enter the parameter setting mode.
2. Back to the function setting mode.
3. Switch the monitor mode.

4 Adjust setting mode and parameters

5 Display

6 Indicator (standard keypad only)

7 Frequency pot (standard keypad only)

8 Drive start key :
1. Blinking: accelerating/ decelerating.
2. Light on: constant speed.
3. Light off: stops.

9 1. Drive stops (cut off the output frequency of terminals)
2. Fault reset

LED basic keypad
KP-601A

Model Number Scheme

Product Series
RM6G1
RM6G1e

Input Voltage
2 : AC 200~240V
4 : AC 380~480V

Model Number
RM6G1e - 2 A005 B 3

Input Power
1 : Single-phase
3 : Three-phase

Brake Type
B : Built-in braking transistor
E : Without braking transistor

RM6G1e Specifications (3 in 1)

Model Case (RM6G1e-□A□□□□□)	2A005B1	2A007B1	2A010B1	2A005B3	2A007B3	2A010B3	2A016B3	2A022B3	4A003B3	4A004B3	4A005B3	4A009B3	4A012B3	
Maximum Applicable Motor (HP/kW)	Heavy duty	0.5 / 0.4	1 / 0.75	2 / 1.5	0.5 / 0.4	1 / 0.75	2 / 1.5	3 / 2.2	5 / 3.7	0.5 / 0.4	1 / 0.75	2 / 1.5	3 / 2.2	5 / 3.7
	Normal duty	1 / 0.75	2 / 1.5	3 / 2.2	1 / 0.75	2 / 1.5	3 / 2.2	5 / 3.7	7.5 / 5.5	1 / 0.75	2 / 1.5	3 / 2.2	5 / 3.7	7.5 / 5.5
Rated Output Capacity (kVA)	Heavy duty	1.1	1.9	3	1.1	1.9	3	4.2	6.5	1.1	1.9	3	4.6	6.9
	Normal duty	1.6	2.6	3.8	1.6	2.6	3.8	5.8	8.1	1.8	2.7	3.8	6.9	8.6
Rated Output Current (A)	Heavy duty	3	5	8	3	5	8	11	17	1.5	2.5	4	6	9
	Normal duty	4.2	6.8	10	4.2	6.8	10	15.2	21.3	2.4	3.5	5	9	11.3
Maximum Output Voltage (V)	Three-phase 200~240V (Correspond to input voltage)								Three-phase 380~480V (Correspond to input voltage)					
Range of Output Frequency (Hz)	0.1~599.00Hz													
Power Source (ø, V, Hz)	Single-phase 200~240V 50/60Hz				Three-phase 200~240V 50/60Hz				Three-phase 380~480V 50/60Hz					
Input Current (A)	Heavy duty	7	13.5	19	4	6	10	14	18	2	3.5	5	8	12
	Normal duty	9.7	18.1	23.8	5	8	12	18	25.2	2.8	4.2	6	12	13.4
Permissible AC Power Source Fluctuation	170~264V 50/60Hz / ±5%								323~528V 50/60Hz / ±5%					
Overload Protection	Heavy duty	150% of drive rated output current for 1 min												
	Normal duty	120% of drive rated output current for 1 min												
Cooling Type	Natural cooling	Fan cooling	Natural cooling	Fan cooling	Natural cooling	Fan cooling	Natural cooling	Fan cooling						
Applicable Safety Standards	UL61800-5-1, CSA C22.2 NO.274, EN61800-3, EN61800-5-1													
Protective Structure	IP20													
Weight (kg)	1.8	1.8	1.9	1.8	1.8	1.8	2.0	2.1	1.8	1.8	1.9	2.0	2.0	
Case Code	Case1													



RM6G1 Three-phase 200V Specifications

Model Case (RM6G1-2A □□□ B3/E3)		005	007	010	016	022	031	042	060	075	090	112	150	185	220	275	346	410	500	700	840	
Maximum Applicable Motor (HP/kW)	Heavy duty	0.5 0.4	1 0.75	2 1.5	3 2.2	5 3.7	7.5 5.5	10 7.5	15 11	20 15	25 18.5	30 22	40 30	50 37	60 45	75 55	100 75	125 90	150 110	200 160	250 200	
	Normal duty	1 0.75	2 1.5	3 2.2	5 3.7	7.5 5.5	10 7.5	15 11	20 15	25 18.5	30 22	40 30	50 37	60 45	75 55	100 75	125 90	150 110	175 132	250 200	300 220	
Rated Output Capacity (kVA)	Heavy duty	1.1	1.9	3	4.2	6.5	9.5	13	18	24	29	34	44	57	70	84	112	132	165	223	267	
	Normal duty	1.6	2.6	3.8	5.8	8.1	12	16	23	29	34	43	57	70	84	105	132	156	191	267	321	
Rated Output Current (A)	Heavy duty	3	5	8	11	17	25	33	46	63	75	90	115	150	185	220	295	346	432	585	700	
	Normal duty	4.2	6.8	10	15.2	21.3	31	42	60	75	90	112	150	185	220	275	346	410	500	700	840	
Maximum Output Voltage (V)	Three-phase 200~240V (Correspond to input voltage)																					
Range of Output Frequency (Hz)	0.1~599.00Hz																					
Power Source (ø, V, Hz)	Three-phase 200~240V 50/60Hz																					
Input Current (A)	Heavy duty	5	6	10	14	18	30	40	60	72	86	103	132	183	211	240	280	330	405	550	660	
	Normal duty	6.1	8	12	18	25.2	41	56	68	86	103	128	183	211	240	280	330	385	470	660	792	
Permissible AC Power Source Fluctuation	170~264V 50/60Hz / ±5%																					
Overload Protection	Heavy duty	150% of drive rated output current for 1 min																				
	Normal duty	120% of drive rated output current for 1 min																				
Cooling Type	Natural cooling	Fan cooling																				
Applicable Safety Standards	UL61800-5-1, CSA C22.2 NO.274, EN61800-3, EN61800-5-1																					
Protective Structure	IP20												IP00 (IP20 OPTION)									
Weight (kg)	3.0	3.0	3.0	3.0	3.0	3.0	5.4	5.7	12.4	13.1	14.7	14.8	42.7	44.3	46.3	63.6	89	90	164	167		
Case Code	Case 2						Case 3		Case 4				Case 5			Case 6	Case 7		Case 8			



RM6G1 Three-phase 400V Specifications

Model Case (RM6G1-4A □□□ B3/E3)		004	005	009	012	018	023	031	039	045	058	075	091	110	144	180	216	253	304	377	415	480	585	700	860	960		
Maximum Applicable Motor (HP/kW)	Heavy duty	1 0.75	2 1.5	3 2.2	5 3.7	7.5 5.5	10 7.5	15 11	20 15	25 18.5	30 22	40 30	50 37	60 45	75 55	100 75	125 90	150 110	175 132	200 160	250 200	300 220	350 250	420 315	500 375	600 450		
	Normal duty	2 1.5	3 2.2	5 3.7	7.5 5.5	10 7.5	15 11	20 15	25 18.5	30 22	40 30	50 37	60 45	75 55	100 75	125 90	150 110	175 132	200 160	250 200	300 220	350 250	420 315	500 375	600 450	700 500		
Rated Output Capacity (kVA)	Heavy duty	1.9	3	4.6	6.9	11	14	18	23	30	34	46	57	69	88	114	137	165	193	236	287	329	366	446	533	660		
	Normal duty	2.7	3.8	6.9	8.6	14	18	24	30	34	44	57	69	84	110	137	165	193	232	287	316	366	446	533	655	732		
Rated Output Current (A)	Heavy duty	2.5	4	6	9	14	18	24	30	39	45	61	75	91	115	150	180	216	253	310	377	432	480	585	700	866		
	Normal duty	3.5	5	9	11.3	18	23	31	39	45	58	75	91	110	144	180	216	253	304	377	415	480	585	700	860	960		
Maximum Output Voltage (V)	Three-phase 380~480V (Correspond to input voltage)																											
Range of Output Frequency (Hz)	0.1~599.00Hz																											
Power Source (ø, V, Hz)	Three-phase 380~480V 50/60Hz																											
Input Current (A)	Heavy duty	3.5	5	8	12	16	22	28	43	47	52	74	86	105	136	155	181	202	217	288	355	401	440	540	650	806		
	Normal duty	4.2	6	12	13.4	20	26	44	47	52	66	86	105	132	162	181	202	217	282	355	385	440	540	627	800	900		
Permissible AC power Source Fluctuation	323~528V 50/60Hz / ±5%																											
Overload Protection	Heavy duty	150% of drive rated output current for 1 min																										
	Normal duty	120% of drive rated output current for 1 min																										
Cooling Type	Natural cooling	Fan cooling																										
Applicable Safety Standards	UL61800-5-1, CSA C22.2 NO.274, EN61800-3, EN61800-5-1																											
Protective Structures	IP20															IP00 (IP20 OPTION)												
Weight (kg)	3.0	3.0	3.0	3.0	3.0	3.1	5.6	5.7	5.8	12.8	12.9	15	15.3	44	45.5	46.4	64	64.5	95	97	159	163	164	217	272			
Case Code	Case 2						Case 3			Case 4			Case 5			Case 6	Case 7		Case 8		Case 9							

*The weights of RM6G1 series in the standard specifications exclude ACL and DCL.



General Specifications

Control Characteristics	Control method		<ul style="list-style-type: none"> • V/F control • PM sensorless vector control • IM sensorless vector control • V/F control + speed feedback card* • PM vector control + speed feedback card* • IM vector control + speed feedback card* 	
	Range of frequency setting		0.01~599Hz	
	Resolution of frequency setting		<ul style="list-style-type: none"> • Digital keypad (KP-601A / KP602): 0.01Hz • RM6G1 Analog signal: 0.03Hz / 60Hz(11bit) • RM6G1e Analog signal: 0.06Hz / 60Hz(10bit) 	
	Resolution of output frequency		0.01Hz	
	Frequency setting signal		-10~10V, 0~10V, 4~20mA, Pulse input*	
	Overload protection		Heavy duty	150% of drive rated output current for 1 min. (Inverse time curve protection)
			Normal duty	120% of drive rated output current for 1 min. (Inverse time curve protection)
	DC braking		<ul style="list-style-type: none"> • Time of DC braking after stop/before start: 0~60.0sec • DC braking frequency at stop: 0.1 ~ 60Hz • DC braking level: 0~150% of rated current 	
	Braking torque		Approximately 20% (with built-in braking resistor connected, braking torque is above 100%)	
	Acceleration / deceleration time		<ul style="list-style-type: none"> • 0.1~3200.0sec or 0.01~320.0sec • The setting of acceleration/deceleration time can be adjusted from 0.01Hz to 599.00Hz. 	
	Stall prevention		<ul style="list-style-type: none"> • Acceleration/constant speed stall prevention (Current level 30~200%) • Stall prevention when decelerate 	
Other functions		Slip compensation, auto-torque compensation, auto-adjustment for output voltage stability, auto-operation for energy-saving, auto-adjustment of switching frequency, restart after instantaneous power failure, speed tracing, overload detection, acceleration/deceleration switch, parameters copy, dynamic brake unit duty control, 16 sections of operating procedures control, kWh accumulation value, counter, timer, Modbus communication, jump frequency, holding frequency, upper and lower limits output frequency, 16 sections speed, S curve acceleration and deceleration, motor temperature display and protection, drive temperature display, cooling fan control, pulse input/output*, password lock, predictive maintenance information, error record, PID control (two-stage PID), upper and lower limits detection feedback, Traverse for textile, switching parameter sets for 2 independent motors, automatic adjustment, torque limit, KEB function, Overvoltage suppress function.		
Expansion card*		PG Card (Line Driver, Open Collector, Resolver, Sin/Cos), Comm. card (Modbus TCP, CANopen)		
Operation Characteristics	Input	Multi-function inputs	<ul style="list-style-type: none"> • 8 sets programmable input terminals: X1~X8 • RM6G1: X8 also has function of pulse input 	
		Analog inputs	<ul style="list-style-type: none"> • Vin1/Vin2*-GND: DC 0~10V or DC -10~+10V • Iin-GND: DC 4~20mA/2~10V or DC 0~20mA/0~10V 	
		Simulate analog inputs	Vin3, Vin4 (the same function as Vin1, Vin2*): set by parameters/communication	
	Output	Multi-function outputs	<ul style="list-style-type: none"> • 5 sets programmable output detection: Ta1-Tb1-Tc1, Ta2-Tb2***-Tc2, Y1-CME, Y2-CME, FM_P-COM* • 2 sets programmable output detection: Y3, Y4 (detection function= Y1, Y2) 	
Analog outputs		<ul style="list-style-type: none"> • "FM+": DC 0~10V • "AM+": DC 0~10V or DC 0~20mA/DC 4~20mA 		
Display	LED keypad (KP-601A) optional		Monitor the frequency of drive, voltage, current, drive temperature, motor temperature, terminal status...etc.	
	LCD keypad (KP-602)		Full-color display, multiple languages and 8 descriptions of monitor modes are shown at the same time.	
Protections	Fault protection	Error trip messages of drive	EEPROM error (EEr), A/D converter error (AdEr), fuse open (SC), under voltage during operation (LE1), drive over current (OC), grounding fault (GF), over voltage (OE), drive overheat (OH), motor overload (OL), drive overload (OL1), system overload (OLO), external fault (EF), keypad interruption during copy (PAdF), input/output under-phase protection (IPLF/OPLF)	
		Warning messages of drive	Power source under voltage (LE), drive output interruption (bb), coast to stop (Fr), dynamic brake transistor over voltage (db), keypad cable trip before connecting (Err_00), keypad cable trip during operation (Err_01), direction command error (dFt), version copy error (FAult)	
Environment	Atmosphere		Non-corrosive or non-conductive, or non-explosive gas or liquid, and non-dusty	
	Surrounding temperature		<ul style="list-style-type: none"> • Heavy duty: -10 °C (14 °F) ~ +50 °C (122 °F) (Non-freezing and non-condensing) • Normal duty: -10 °C (14 °F) ~ +40 °C (104 °F) (Non-freezing and non-condensing) 	
	Storage temperature		-20 °C (-4 °F) ~ +70 °C (158 °F)	
	Relative humidity		90% RH or less (non-condensing atmosphere)	
	Vibration		Less than 5.9m/sec ² (0.6G)	
	Altitude		Less than 1000m (3280 ft.)	

*Items not equipped with RM6G1e

**Items not equipped with RM6G1

Main Circuit Terminal Wiring Diagram

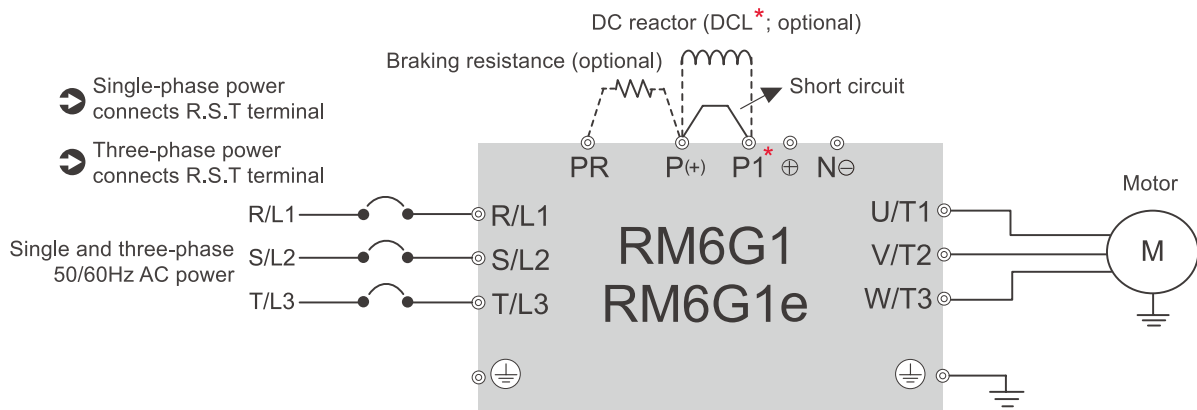

Control Terminal Circuit Wiring Diagram

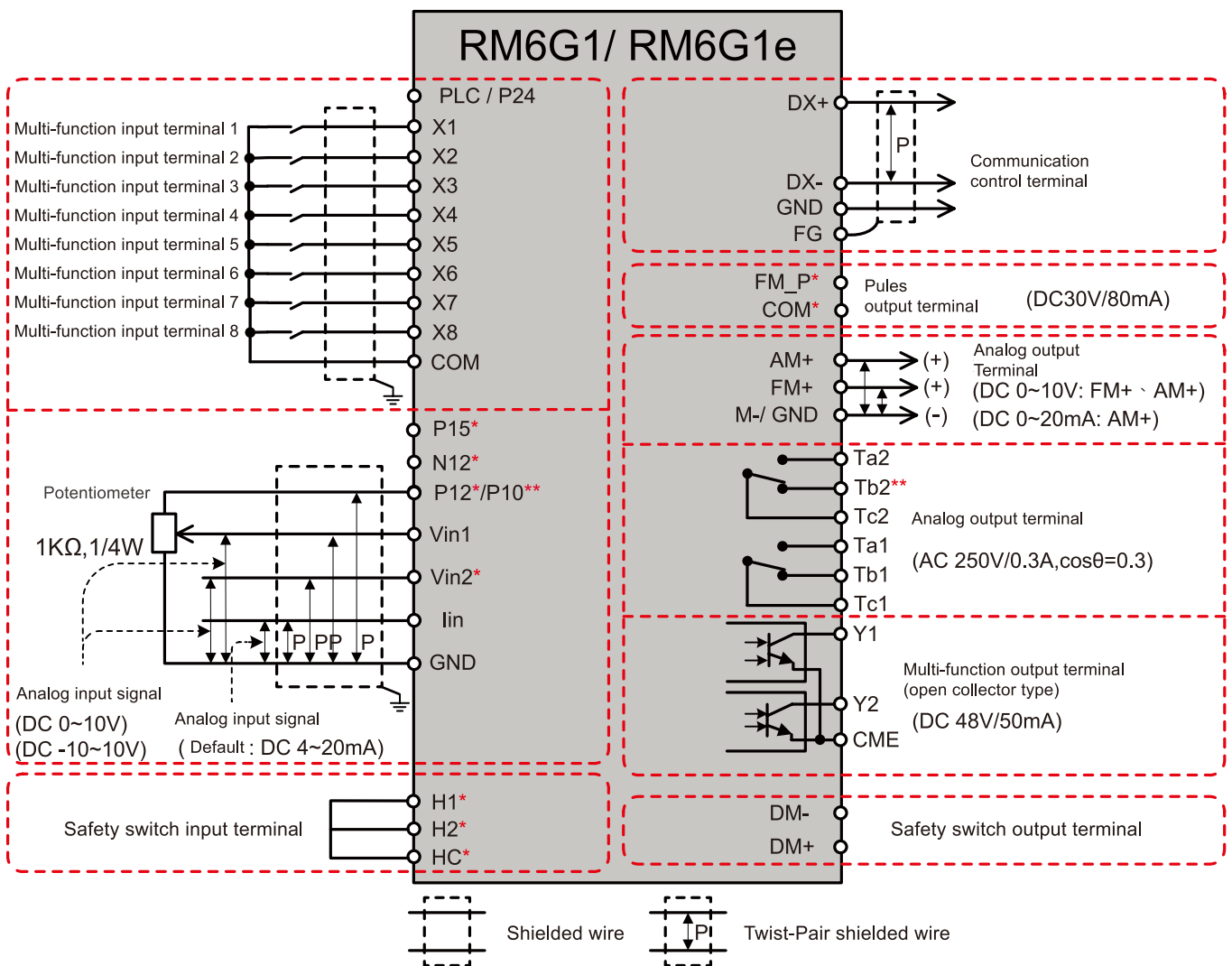

*Items not equipped with RM6G1e

**Items not equipped with RM6G1



Main Circuit Terminals

Symbol	Function	Description
R, S, (L1,L2)	AC power source input terminals	Single-phase; sinusoidal power source input terminals
R, S, T (L1, L2, L3)		Three-phase; sinusoidal power source input terminals
$\oplus \cdot N \ominus$	DC power source input terminals*	External DC power source terminal (Models within 2A150 and within 4A110 have \oplus terminal)
U, V, W (T1, T2, T3)	Drive outputs to motor terminals	Output three-phase variable frequency and voltage to motor
P(+), N \ominus	Dynamic brake unit terminals	The terminals can be connected to dynamic braking unit (option)
P(+), PR	External braking resistor terminals	The terminals can be connected to external brake resistor (option)
P(+), P1*	External reactor terminals	The terminal can be connected to DC reactor (DCL) for improving power factor. The original configuration is a jumper.
PE and $\opl�$	Grounding terminals	Ground the drive in compliance with the NEC standard or local electrical code



Control Terminals

Type	Symbol	Function	Description
Control Power	PLC/P24	Power terminal for control device	Output DC+24V; Maximum supplied current is 100mA
	P12*/P10**		Output DC+12V (RM6G1e output DC+10V); Maximum supplied current is 20mA
	N12*		Output DC-12V; Maximum supplied current is 20mA
Input Terminals	GND	Common of analog input terminals	Common terminal for control power (P12 - N12 - P15) and analog input terminals (Vin1/ Vin2/ lin)
	X1	Multi-function input terminal 1	<ul style="list-style-type: none"> Set the function at H1-00. Default setting: Forward command
	X2	Multi-function input terminal 2	<ul style="list-style-type: none"> Set the function at H1-01. Default setting: Reverse command
	X3	Multi-function input terminal 3	<ul style="list-style-type: none"> Set the function at H1-02. Default setting: Jog command
	X4	Multi-function input terminal 4	<ul style="list-style-type: none"> Set the function at H1-03. Default setting: External fault command
	X5	Multi-function input terminal 5	<ul style="list-style-type: none"> Set the function at H1-04. Default setting: Reset command
	X6	Multi-function input terminal 6	<ul style="list-style-type: none"> Set the function at H1-05. Default setting: Disable
	X7	Multi-function input terminal 7	<ul style="list-style-type: none"> Set the function at H1-06. Default setting: Disable
	X8	Multi-function input terminal 8	<ul style="list-style-type: none"> Set the function at H1-07. Default setting: Disable
	COM	Common of digital input terminals	<ul style="list-style-type: none"> Common of input control terminal (X1~X8) Control power (PLC), pulse input signal (FM_P)
	Vin1	Analog input terminal 1	<ul style="list-style-type: none"> Input range DC 0~10V or DC -10~10V, input impedance 20kΩ
	Vin2*	Analog input terminal 2	<ul style="list-style-type: none"> Selective function of DIP switch-SW2: Thermistor or external voltage signal
	lin	Analog input terminal 3	<ul style="list-style-type: none"> Selective function of DIP switch-SW1: Current signal or voltage signal
Output Terminals	FM_P*	Pulse output signal terminal	<ul style="list-style-type: none"> NPN open collector isolated output: Maximum value: 30VDC/80mA. Default setting: Output frequency
	AM +	Analog output terminal 1	<ul style="list-style-type: none"> Selective output signal-JP4: Current signal or voltage signal
	FM +	Analog output terminal 2	<ul style="list-style-type: none"> Set the function at H4-00. Default setting: Output frequency
	M -*/GND	Common of analog output terminals	<ul style="list-style-type: none"> Common of analog output terminal
	Ta1	Multi-function output terminals (relay type)	<ul style="list-style-type: none"> Set the function at H2-04. Default setting: Error detection
	Tb1		<ul style="list-style-type: none"> Set the function at H2-04. Default setting: Error detection
	Tc1		<ul style="list-style-type: none"> Common of Ta1, Tb1 terminals
	Ta2	Multi-function output terminals (open collector type)	<ul style="list-style-type: none"> Set the function at H2-05. Default setting: Detection during operation
	Tb2**		<ul style="list-style-type: none"> Set the function at H2-05. Default setting: Detection during operation
	Tc2		<ul style="list-style-type: none"> Ta2 common terminal
	Y1	Multi-function output terminals (open collector type)	<ul style="list-style-type: none"> Set the function at H2-00. Default setting: Zero speed detection
Y2	<ul style="list-style-type: none"> Set the function at H2-01. Default setting: Zero speed detection 		
CME	<ul style="list-style-type: none"> Common of Y1, Y2 terminals 		



Communication Control Terminals

Type	Symbol	Function	Description
Communication Terminals	DX +	MODBUS	<ul style="list-style-type: none"> With HMI/NB to control the inverter Communication protocol: Modbus (interface: RS-485) Terminal resistor switch-DSW1, terminal resistor=120Ω
	DX -	Communication terminals	
	GND	Common terminals of communication terminals	
	FG	MODBUS Communication terminal	Grounding terminal of shielding wire

*Items not equipped with RM6G1e

**Items not equipped with RM6G1

Peripheral Equipment of Drive

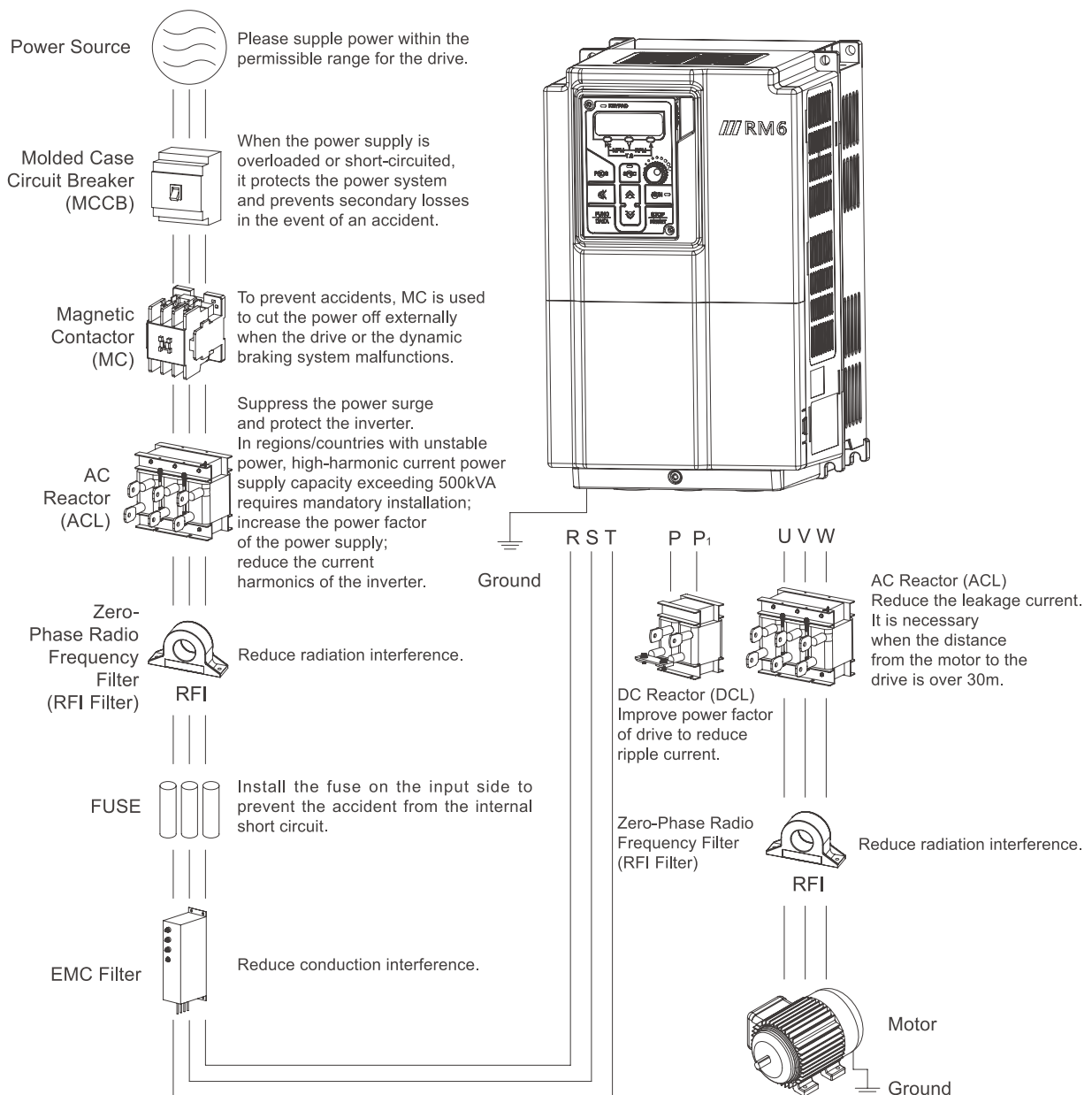

ACL Installation Guide:

RST input side:

- When the power capacity is over 500 kVA or 10 times larger than the rated capacity of drive.
- When the heater (with the SCR), air compressor, high frequency equipment or welding machine is installed at the same power source system, the harmonic current will interfere the drive.

UVW output side:

- Cable length between the drive and the motor is over 30 meters or multiple motors are used in parallel.

RM6G1 series: ACL is standard equipment. 200V: 2A346E3 and above; 400V: 4A180E3 and above.

DCL standard configuration. 200V: 2A700E3 and above; 400V: 4A304E3 and above.

Note: For detailed matching equipment selection.

RM6G1e Dimensions

Case 1

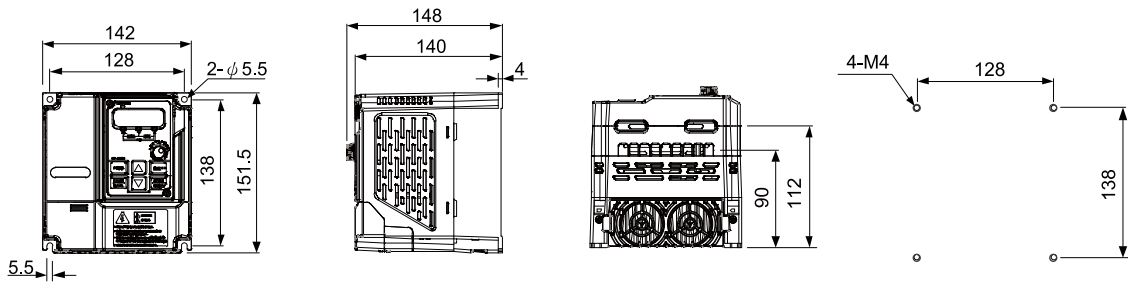

Unit: mm

RM6G1 Dimensions

Case 2~4

Internal cooling type

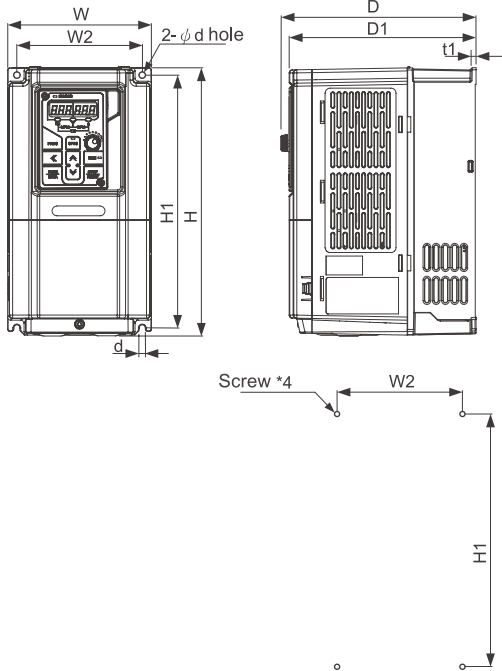

External cooling type

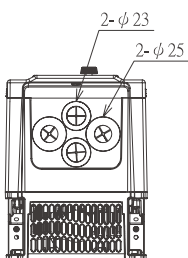
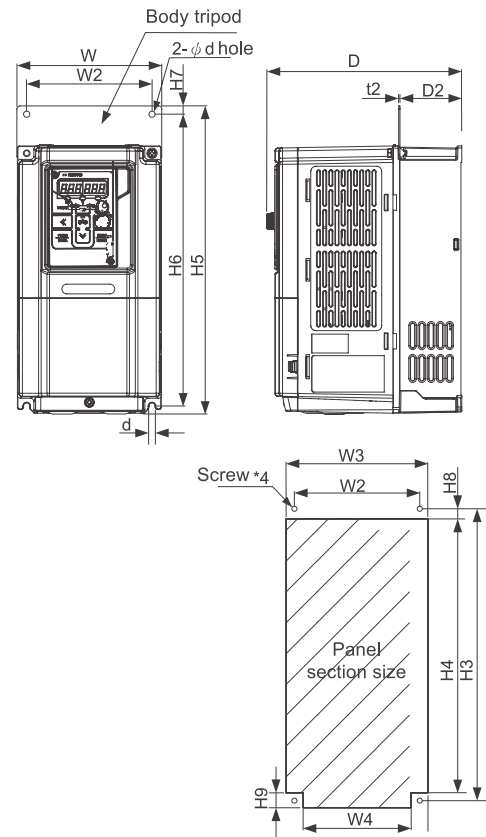

Case 2

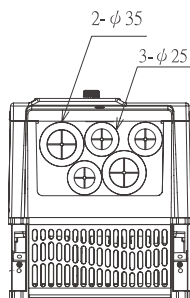

Case 3

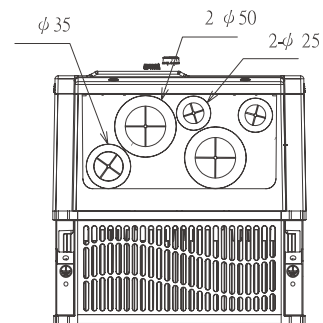

Case 4

Unit: mm

Case 5~9

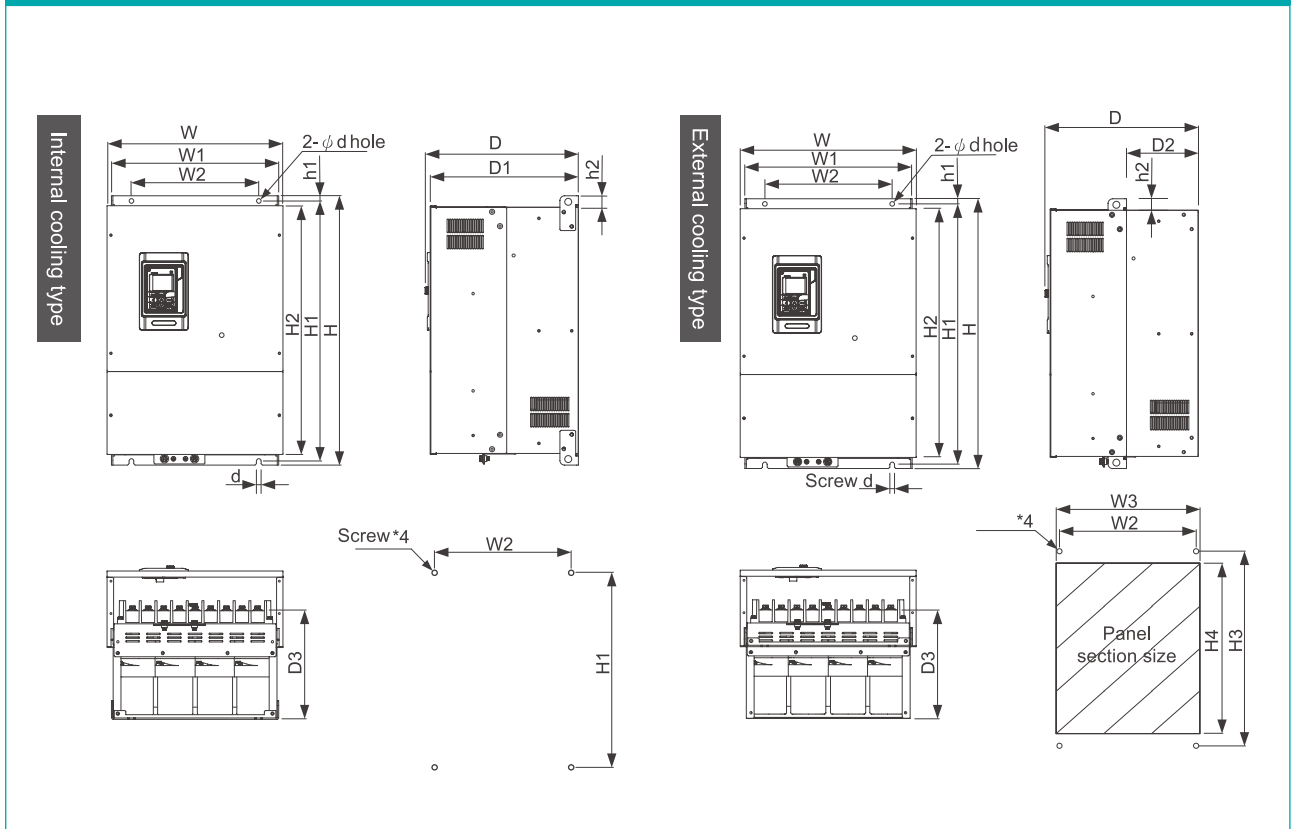

Unit: mm

RM6G1 Dimensions

Case	type		Dimension (mm)																							Screw	
	200V	400V	W	W1	W2	W3	W4	H	H1	H2	H3	H4	H5	H6	H7	H8	H9	h1	h2	t1	t2	D	D1	D2	D3	d	(mm)
CASE2	005~031	004~023	140	-	122	138.5	105	260	246	-	284	267	300	284	8	10	14.5	-	-	4.7	1.2	190	182	60	-	6	M5
CASE3	042~060	031~045	180	-	162	178.5	149	290	277	-	313	290	329	313	8	10	20	-	-	9	1.6	207	199	74	-	6.5	M5
CASE4	075~150	058~110	250	-	230	248.5	212	400	380	-	427	396	448	427	10	11.5	29	-	-	9.5	2	258	250	103	-	9	M8
CASE5	185~275	144~216	386	361	275	365	-	584	562	539	564	545	-	-	-	-	-	11	25	-	-	331	323	155	242	10	M8
CASE6	346	253~304	446	418	275	427	-	685	660	630	662	634	-	-	-	-	-	14	30	-	-	334	326	163	246	12	M10
CASE7	410~500	377~415	508	479	275	487	-	818	785	751	788	758	-	-	-	-	-	19	35	-	-	374	366	183	257	15	M12
CASE8	700~840	480~700	696	654	580	657	-	1000	974	929	978	936	-	-	-	-	-	15	39	-	-	413	405	182	294	15	M12
CASE9	-	860~960	992	954	710	958	-	1030	1003	963	1007	968	-	-	-	-	-	15	39	-	-	427	419	185	308	15	M12

More product detail information, please scan the QR-code to download operation manual.



Green Tech

科技創未來 · 打造綠生活 **Green Life**

Formosa Sika Deer, an endemic species in Taiwan. Once, they were critically endangered. Fortunately a success restoration has been achieved in southern Taiwan during 1994. Now, the Formosa Sika Deer should live prosperous on the Formosa Island for every spring to come.

RHYMEBUS has been deeply dedicating in Taiwan. With flexible green energy techniques and serices in rarious industry applications, looks forward to contributing to the global natural environment and ecology.



40768 台中市工業區 33 路 17 號
TEL+886-4-23595237 FAX+886-4-23595235
NO. 17, 33rd Road, Taichung Industrial Park, Taichung, Taiwan 40768
www.rhymebus.com.tw E-mail: inverter@mail.rhymebus.com.tw
XB200206 / 1809 Ver 1 / 2604



(*Information subject to change without notice.)